

# Full bridge current driven vertical deflection booster

## TDA4866

### FEATURES

- Fully integrated, few external components
- No additional components in combination with the deflection controller TDA485x, TDA4841PS
- Pre-amplifier with differential high CMRR current mode inputs
- Low offsets
- High linear sawtooth signal amplification
- High efficient DC-coupled vertical output bridge circuit
- Powerless vertical shift
- High deflection frequency up to 160 Hz
- Power supply and flyback supply voltage independent adjustable to optimize power consumption and flyback time
- Excellent transition behaviour during flyback
- Guard circuit for screen protection.

### GENERAL DESCRIPTION

The TDA4866 is a power amplifier for use in 90 degree colour vertical deflection systems for frame frequencies of 50 to 160 Hz. The circuit provides a high CMRR current driven differential input. Due to the bridge configuration of the two output stages DC-coupling of the deflection coil is achieved. In conjunction with TDA485x, TDA4841PS the ICs offer an extremely advanced system solution.

### QUICK REFERENCE DATA

| SYMBOL                       | PARAMETER  | CONDITIONS | MIN. | TYP. | MAX. | UNIT |
|------------------------------|--|------------|------|------|------|------|
| <b>DC supply; note 1</b>     |  |            |      |      |      |      |
| $V_P$                        | supply voltage (pin 3)                                     |            | 8.2  | –    | 25   | V    |
| $V_{FB}$                     | flyback supply voltage (pin 7)                             | note 2     | –    | –    | 60   | V    |
| $I_q$                        | quiescent current (pin 7)                                  |            | –    | 7    | 10   | mA   |
| <b>Vertical circuit</b>      |  |            |      |      |      |      |
| $I_{defl}$                   | deflection current (peak-to-peak value; pins 4 and 6)      |            | 0.6  | –    | 2    | A    |
| $I_{id}$                     | differential input current (peak-to-peak value)            | note 3     | –    | ±500 | ±600 | µA   |
| <b>Flyback generator</b>     |  |            |      |      |      |      |
| $I_{FB}$                     | maximum current during flyback (peak-to-peak value; pin 7) |            | –    | –    | 2    | A    |
| <b>Guard circuit; note 1</b> |  |            |      |      |      |      |
| $V_g$                        | guard voltage  | guard on   | 7.5  | 8.5  | 10   | V    |
| $I_g$                        | guard current  | guard on   | 5    | –    | –    | mA   |

### Notes

1. Voltages refer to pin 5 (GND).
2. Up to  $60\text{ V} \geq V_{FB} \geq 40\text{ V}$  a decoupling capacitor  $C_{FB} = 22\text{ }\mu\text{F}$  (between pin 7 and pin 5) and a resistor  $R_{FB} = 100\text{ }\Omega$  (between pin 7 and  $V_{FB}$ ) are required (see Fig.4).
3. Differential input current  $I_{id} = I_1 - I_2$ .

# Full bridge current driven vertical deflection booster

TDA4866

## ORDERING INFORMATION

| TYPE NUMBER | PACKAGE |   |          |
|-------------|---------|---|----------|
|             | NAME    | DESCRIPTION                                   | VERSION  |
| TDA4866     | SIL9P   | plastic single in-line power package; 9 leads | SOT131-2 |

## BLOCK DIAGRAM

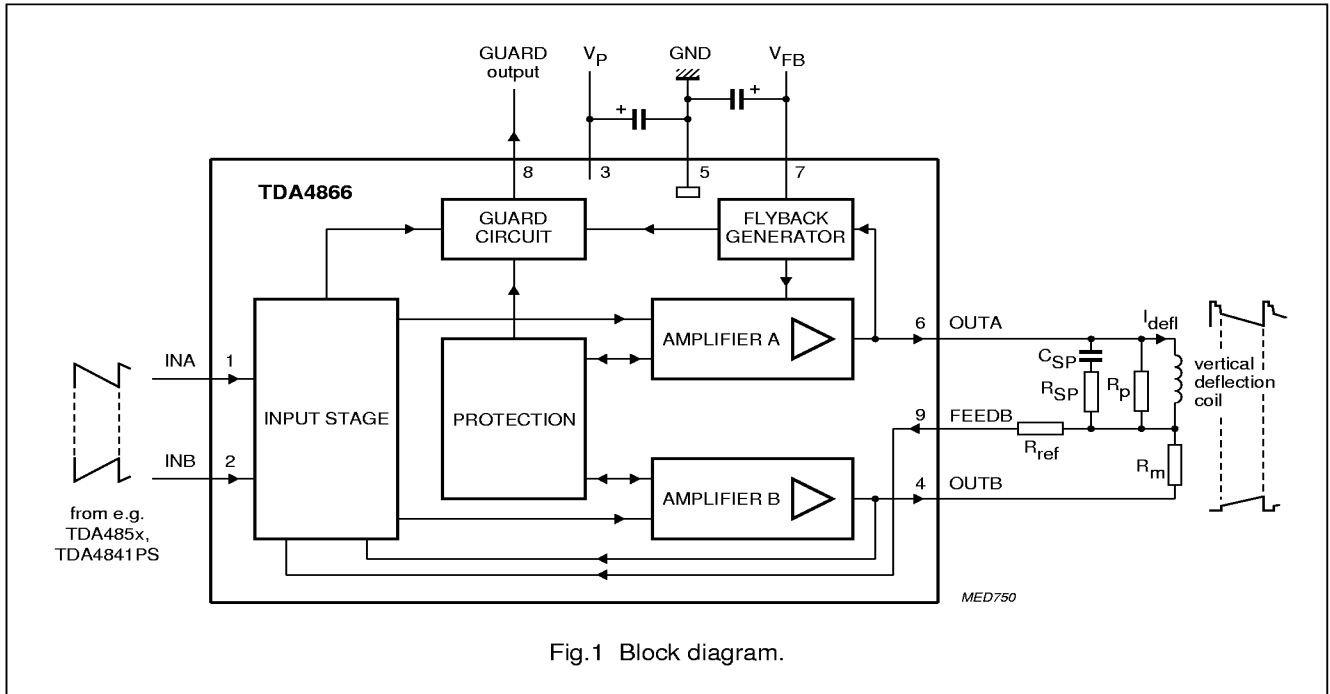

Fig.1 Block diagram.

## PINNING

| SYMBOL          | PIN | DESCRIPTION            |
|-----------------|-----|------------------------|
| INA             | 1   | input A                |
| INB             | 2   | input B                |
| V <sub>P</sub>  | 3   | supply voltage         |
| OUTB            | 4   | output B               |
| GND             | 5   | ground                 |
| OUTA            | 6   | output A               |
| V <sub>FB</sub> | 7   | flyback supply voltage |
| GUARD           | 8   | guard output           |
| FEEDB           | 9   | feedback input         |

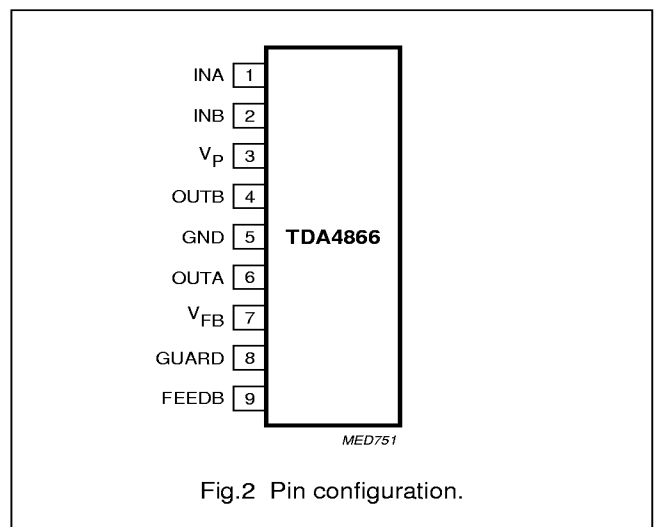

Fig.2 Pin configuration.

## Full bridge current driven vertical deflection booster

TDA4866

### FUNCTIONAL DESCRIPTION

The TDA4866 consists of a differential input stage, two output stages, a flyback generator, a protection circuit for the output stages and a guard circuit.

#### Differential input stage

The differential input stage has a high CMRR differential current mode input (pins 1 and 2) that results in a high electro-magnetic immunity and is especially suitable for driver units with differential (e.g. TDA485x, TDA4841PS) and single ended current signals. Driver units with voltage outputs are simply applicable as well (e.g. two additional resistors are required).

The differential input stage delivers the driver signals for the output stages.

#### Output stages

The two output stages are current driven in opposite phase and operate in combination with the deflection coil in a full bridge configuration. Therefore the TDA4866 requires no external coupling capacitor (e.g. 2200  $\mu$ F) and operates with one supply voltage  $V_P$  and a separate adjustable flyback supply voltage  $V_{FB}$  only. The deflection current through the coil ( $I_{defl}$ ) is measured with the resistor  $R_m$  which produces a voltage drop ( $U_{rm}$ ) of:  $U_{rm} \approx R_m \times I_{defl}$ . At the feedback input (pin 9) a part of  $I_{defl}$  is fed back to the input stage. The feedback input has a current input characteristic which holds the differential voltage between pin 9 and the output pin 4 on zero. Therefore the feedback current ( $I_g$ ) through  $R_{ref}$  is:

$$I_g \approx \frac{R_m}{R_{ref}} \times I_{defl}$$

The input stage directly compares the driver currents into pins 1 and 2 with the feedback current  $I_g$ . Any difference of this comparison leads to a more or less driver current for the output stages. The relation between the deflection current and the differential input current ( $I_{id}$ ) is:

$$I_{id} = I_g \approx \frac{R_m}{R_{ref}} \times I_{defl}$$

Due to the feedback loop gain ( $V_{U loop}$ ) and internal bondwire resistance ( $R_{bo}$ ) correction factors are required to determine the accurate value of  $I_{defl}$ :

$$I_{defl} = I_{id} \times \frac{R_{ref}}{R_m + R_{bo}} \times \left(1 - \frac{1}{V_{U loop}}\right)$$

with  $R_{bo} \approx 70 \text{ m}\Omega$  and  $\left(1 - \frac{1}{V_{U loop}}\right) \approx 0.98$

for  $I_{defl} = 0.7 \text{ A}$ .

The deflection current can be adjusted up to  $\pm 1 \text{ A}$  by varying  $R_{ref}$  when  $R_m$  is fixed to  $1 \Omega$ .

High bandwidth and excellent transition behaviour is achieved due to the transimpedance principle this circuit works with.

#### Flyback generator

During flyback the flyback generator supplies the output stage A with the flyback voltage. This makes it possible to optimize power consumption (supply voltage  $V_P$ ) and flyback time (flyback voltage  $V_{FB}$ ). Due to the absence of a decoupling capacitor the flyback voltage is fully available.

In parallel with the deflection yoke and the damping resistor ( $R_p$ ) an additional RC combination ( $R_{SP}$ ;  $C_{SP}$ ) is necessary to achieve an optimized flyback behaviour.

#### Protection

The output stages are protected against:

- Thermal overshoot
- Short-circuit of the coil (pins 4 and 6).

#### Guard circuit

The internal guard circuit provides a blanking signal for the CRT. The guard signal is active HIGH:

- At thermal overshoot
- When feedback loop is out of range
- During flyback.

The internal guard circuit will not be activated, if the input signals on pins 1 and 2 delivered from the driver circuit are out of range or at short-circuit of the coil (pins 4 and 6).

For this reason an external guard circuit can be applied to detect failures of the deflection (see Fig.6). This circuit will be activated when flyback pulses are missing, which is the indication of any abnormal operation.

# Full bridge current driven vertical deflection booster

TDA4866

## LIMITING VALUES

In accordance with the Absolute Maximum Rating System (IEC 134); voltages referenced to pin 5 (GND); unless otherwise specified.

| SYMBOL     | PARAMETER                           | CONDITIONS | MIN. | MAX.        | UNIT |
|------------|-------------------------------------|------------|------|-------------|------|
| $V_P$      | supply voltage (pin 3)              |            | 0    | 30          | V    |
| $V_{FB}$   | flyback supply voltage (pin 7)      |            | 0    | 60          | V    |
| $I_{FB}$   | flyback supply current              |            | 0    | $\pm 1.8$   | A    |
| $V_1, V_2$ | input voltage                       |            | 0    | $V_P$       | V    |
| $I_1, I_2$ | input current                       |            | 0    | $\pm 5$     | mA   |
| $V_4, V_6$ | output voltage                      |            | 0    | $V_P$       | V    |
| $I_4, I_6$ | output current                      | note 1     | 0    | $\pm 1.8$   | A    |
| $V_9$      | feedback voltage                    |            | 0    | $V_P$       | V    |
| $I_9$      | feedback current                    |            | 0    | $\pm 5$     | mA   |
| $V_8$      | guard voltage                       | note 2     | 0    | $V_P + 0.4$ | V    |
| $I_8$      | guard current                       |            | 0    | $\pm 5$     | mA   |
| $T_{stg}$  | storage temperature                 |            | -20  | +150        | °C   |
| $T_{amb}$  | operating ambient temperature       |            | -20  | +75         | °C   |
| $T_j$      | junction temperature                | note 3     | -20  | +150        | °C   |
| $V_{es}$   | electrostatic handling for all pins | note 4     | -500 | +500        | V    |

## Notes

1. Maximum output currents  $I_4$  and  $I_6$  are limited by current protection.
2. For  $V_P > 13$  V the guard voltage  $V_8$  is limited to 13 V.
3. Internally limited by thermal protection; switching point  $\geq 150$  °C.
4. Equivalent to discharging a 200 pF capacitor through a 0  $\Omega$  series resistor.

## THERMAL CHARACTERISTICS

| SYMBOL         | PARAMETER   | VALUE | UNIT |
|----------------|---|-------|------|
| $R_{th(j-mb)}$ | thermal resistance from junction to mounting base | 4     | K/W  |

# Full bridge current driven vertical deflection booster

TDA4866

## CHARACTERISTICS

$V_P = 15\text{ V}$ ;  $T_{\text{amb}} = 25\text{ }^\circ\text{C}$ ;  $V_{\text{FB}} = 40\text{ V}$ ; voltages referenced to pin 5 (GND); parameters are measured in test circuit (see Fig.3); unless otherwise specified.

| SYMBOL                       | PARAMETER   | CONDITIONS   | MIN.      | TYP.      | MAX.      | UNIT            |
|------------------------------|---|--|-----------|-----------|-----------|-----------------|
| $V_P$                        | supply voltage (pin 3)  |  | 8.2       | –         | 25        | V               |
| $V_{\text{FB}}$              | flyback supply voltage (pin 7)  | note 1   | $V_P + 6$ | –         | 60        | V               |
| $I_{\text{FB}}$              | quiescent feedback current (pin 7)  | no load; no signal   | –         | 7         | 10        | mA              |
| <b>Input stage</b>           |   |  |           |           |           |                 |
| $I_{\text{id(p-p)}}$         | differential input current ( $I_{\text{id}} = I_1 - I_2$ ) (peak-to-peak value) |  | –         | $\pm 500$ | $\pm 600$ | $\mu\text{A}$   |
| $I_{1,2(\text{p-p})}$        | single ended input current (peak-to-peak value)                                 | note 2   | 0         | $\pm 300$ | $\pm 600$ | $\mu\text{A}$   |
| CMRR                         | common mode rejection ratio   | note 3   | –         | –54       | –         | dB              |
| $V_1$                        | input clamp voltage   | $I_1 = 300\text{ }\mu\text{A}$   | 2.7       | 3.0       | 3.3       | V               |
| $V_2$                        | input clamp voltage   | $I_2 = 300\text{ }\mu\text{A}$   | 2.7       | 3.0       | 3.3       | V               |
| $TC_{i,1}$                   | input clamp signal TC on pin 1  |  | 0         | –         | $\pm 800$ | $\mu\text{V/K}$ |
| $TC_{i,2}$                   | input clamp signal TC on pin 2  |  | 0         | –         | $\pm 800$ | $\mu\text{V/K}$ |
| $V_1 - V_2$                  | differential input voltage  | $I_{\text{id}} = 0$  | 0         | –         | $\pm 10$  | mV              |
| $I_9$                        | feedback current  |  | –         | $\pm 500$ | $\pm 600$ | $\mu\text{A}$   |
| $V_9$                        | feedback voltage  |  | 1         | –         | $V_P - 1$ | V               |
| $I_{\text{id(offset)}}$      | differential input offset current ( $I_{\text{id(offset)}} = I_1 - I_2$ )       | $I_{\text{defl}} = 0$ ; $R_{\text{ref}} = 1.5\text{ k}\Omega$ ; $R_{\text{m}} = 1\text{ }\Omega$ | 0         | –         | $\pm 20$  | $\mu\text{A}$   |
| $C_{i\text{INA}}$            | input capacity pin 1 referenced to GND  |  | –         | –         | 5         | pF              |
| $C_{i\text{INB}}$            | input capacity pin 2 referenced to GND  |  | –         | –         | 5         | pF              |
| <b>Output stages A and B</b> |   |  |           |           |           |                 |
| $I_4$                        | output current  |  | –         | –         | $\pm 1$   | A               |
| $I_6$                        | output current  |  | –         | –         | $\pm 1$   | A               |
| $V_6$                        | output A saturation voltage to GND  | $I_6 = 0.7\text{ A}$   | –         | 1.3       | 1.5       | V               |
|                              |   | $I_6 = 1.0\text{ A}$   | –         | 1.6       | 1.8       | V               |
| $V_{6,3}$                    | output A saturation voltage to $V_P$  | $I_6 = 0.7\text{ A}$   | –         | 2.3       | 2.9       | V               |
|                              |   | $I_6 = 1.0\text{ A}$   | –         | 2.7       | 3.3       | V               |
| $V_4$                        | output B saturation voltage to GND  | $I_4 = 0.7\text{ A}$   | –         | 1.3       | 1.5       | V               |
|                              |   | $I_4 = 1.0\text{ A}$   | –         | 1.6       | 1.8       | V               |
| $V_{4,3}$                    | output B saturation voltage to $V_P$  | $I_4 = 0.7\text{ A}$   | –         | 1.0       | 1.6       | V               |
|                              |   | $I_4 = 1.0\text{ A}$   | –         | 1.3       | 1.9       | V               |
| LE                           | linearity error   | $I_{\text{defl}} = \pm 0.7\text{ A}$ ; note 4  | –         | –         | 2         | %               |
| $V_4$                        | DC output voltage   | $I_{\text{id}} = 0\text{ A}$ ; closed-loop   | 6.6       | 7.2       | 7.8       | V               |
| $V_6$                        | DC output voltage   | $I_{\text{id}} = 0\text{ A}$ ; closed-loop   | 6.6       | 7.2       | 7.8       | V               |
| $G_{\text{oi}}$              | open-loop current gain ( $I_{4,6}/I_{\text{id}}$ )                              | $I_{4,6} < 100\text{ mA}$ ; note 5   | –         | 100       | –         | dB              |
| $G_{\text{ofb}}$             | open-loop current gain ( $I_{4,6}/I_9$ )  | $I_{4,6} < 100\text{ mA}$ ; note 5   | –         | 100       | –         | dB              |
| $G_{\text{ifb}}$             | current ratio ( $I_{\text{id}}/I_9$ )   | closed-loop  | –         | –0.2      | –         | dB              |

# Full bridge current driven vertical deflection booster

TDA4866

| SYMBOL                    | PARAMETER  | CONDITIONS  | MIN.                 | TYP.    | MAX.                 | UNIT |
|---------------------------|--|---|----------------------|---------|----------------------|------|
| $I_{\text{defl(ripple)}}$ | output ripple current as a function of supply ripple | $V_{\text{P(ripple)}} = \pm 0.5 \text{ V}$ ;<br>$I_{\text{id}} = 0$ ; closed-loop | –                    | $\pm 1$ | –                    | mA   |
| <b>Flyback generator</b>  |  |   |                      |         |                      |      |
| $V_{7,6}$                 | voltage drop during flyback reverse                  | $I_{\text{defl}} = 0.7 \text{ A}$   | –                    | –2.0    | –3.0                 | V    |
|                           |  | $I_{\text{defl}} = 1.0 \text{ A}$   | –                    | –2.3    | –3.5                 | V    |
|                           | forward  | $I_{\text{defl}} = 0.7 \text{ A}$   | –                    | +5.6    | +6.1                 | V    |
|                           |  | $I_{\text{defl}} = 1.0 \text{ A}$   | –                    | +5.9    | +6.5                 | V    |
| $V_6$                     | switching on threshold voltage                       |   | $V_{\text{P}} - 1$   | –       | $V_{\text{P}} + 1.5$ | V    |
| $V_6$                     | switching off threshold voltage                      |   | $V_{\text{P}} - 1.5$ | –       | $V_{\text{P}} + 1$   | V    |
| $I_7$                     | flyback current during flyback                       |   | –                    | –       | $\pm 1$              | A    |
| <b>Guard circuit</b>      |  |   |                      |         |                      |      |
| $V_8$                     | output voltage                                       | guard on  | 7.5                  | 8.5     | 10                   | V    |
| $V_8$                     | output voltage                                       | guard on; $V_{\text{P}} = 8.2 \text{ V}$  | 6.9                  | –       | $V_{\text{P}} - 0.4$ | V    |
| $I_8$                     | output current                                       | guard on  | 5                    | –       | –                    | mA   |
| $V_8$                     | output voltage                                       | guard off   | –                    | –       | 0.4                  | V    |
| $I_8$                     | output current                                       | guard off; $V_8 = 5 \text{ V}$  | 0.5                  | 1       | 1.5                  | mA   |
| $V_{8(\text{ext.})}$      | allowable external voltage on pin 8                  |   | 0                    | –       | 13                   | V    |
|                           |  | $V_{\text{P}} \leq 13 \text{ V}$  | 0                    | –       | $V_{\text{P}} + 0.3$ | V    |

**Notes**

- Up to  $60 \text{ V} \geq V_{\text{FB}} \geq 40 \text{ V}$  a decoupling capacitor  $C_{\text{FB}} = 22 \mu\text{F}$  (between pins 7 and 5) and a resistor  $R_{\text{FB}} = 100 \Omega$  (between pin 7 and  $V_{\text{FB}}$ ) are required (see Fig.4).
- Saturation voltages of output stages A and B can be increased in the event of negative input currents  $I_{1,2} < -500 \mu\text{A}$ .
- $D_i = \frac{I_{\text{deflc}}}{I_{\text{idc}}} \times \frac{I_{\text{id}}}{I_{\text{defl}}}$  with  $I_{\text{deflc}}$  = common mode deflection current and  $I_{\text{idc}}$  = common mode input current.
- Deviation of the output slope at a constant input slope.
- Frequency behaviour of  $G_{\text{oi}}$  and  $G_{\text{ofb}}$ :
  - 3 dB open-loop bandwidth ( $-45^\circ$ ) at 15 kHz; second pole ( $-135^\circ$ ) at 1.3 MHz.
  - Open-loop gain at second pole ( $-135^\circ$ ) 55 dB.

# Full bridge current driven vertical deflection booster

TDA4866

## TEST AND APPLICATION INFORMATION

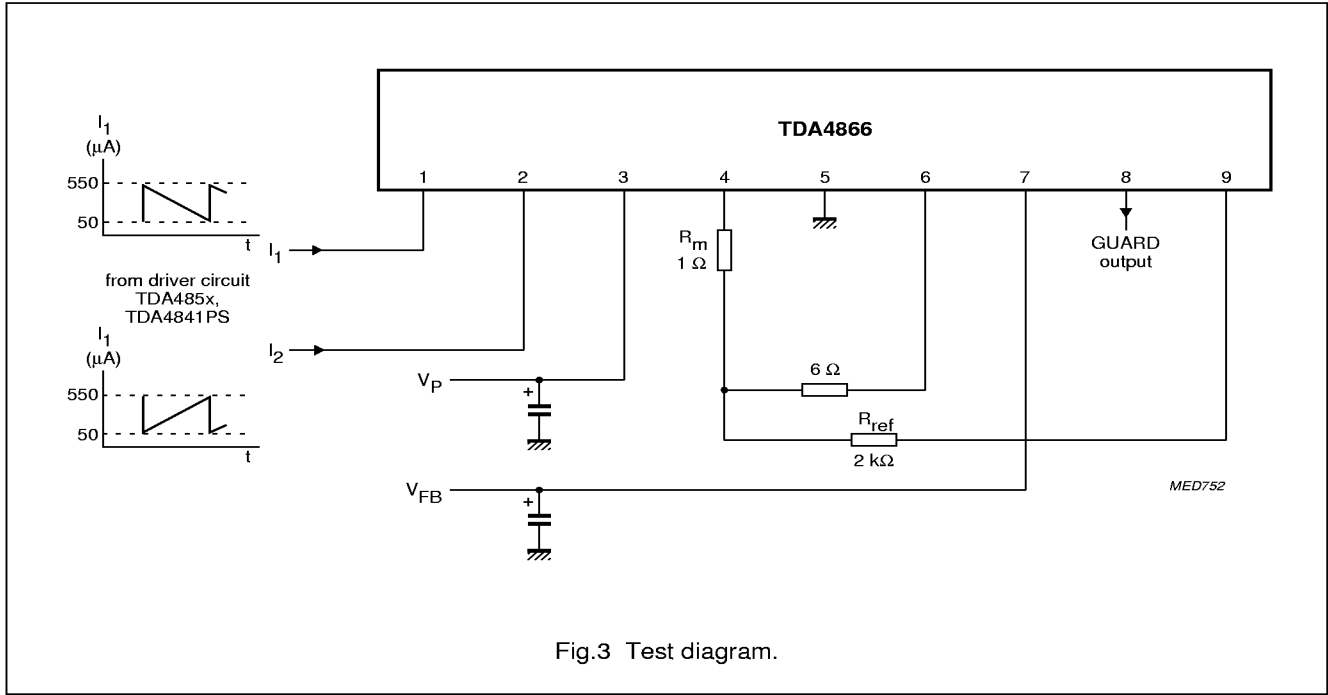

Fig.3 Test diagram.

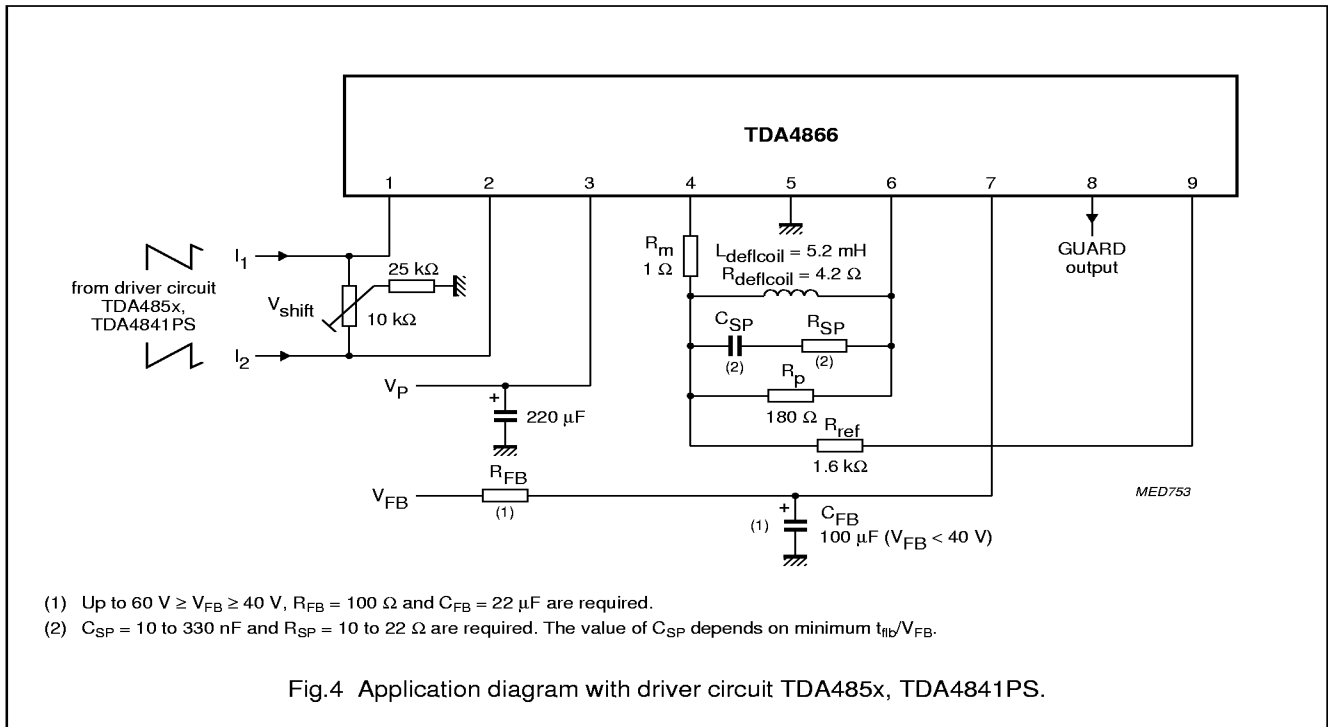

Fig.4 Application diagram with driver circuit TDA485x, TDA4841PS.

# Full bridge current driven vertical deflection booster

TDA4866

## Example

| SYMBOL                               | VALUE                                     | UNIT               |
|--------------------------------------|---|--------------------|
| <b>Values given from application</b> |   |                    |
| $I_{\text{defl(max)}}$               | 0.71                                      | A                  |
| $L_{\text{deflcoil}}$                | 5.2                                       | mH                 |
| $R_{\text{deflcoil}}$                | 5.4 [= 4.2 + 7% + $\Delta R(\vartheta)$ ] | $\Omega$           |
| $R_m$                                | 1 (+1%)                                   | $\Omega$           |
| $R_p$                                | 180                                       | $\Omega$           |
| $R_{\text{ref}}$                     | 1.6                                       | k $\Omega$         |
| $V_{\text{FB}}$                      | 35  | V                  |
| $T_{\text{amb}}$                     | +50                                       | $^{\circ}\text{C}$ |
| $T_{\text{deflcoil}}$                | +75                                       | $^{\circ}\text{C}$ |
| $R_{\text{th(j-mb)}}$                | 4   | K/W                |
| $R_{\text{th(mb-amb)}}^{(1)}$        | 8   | K/W                |
| <b>Calculated values</b>             |   |                    |
| $V_P$                                | 8.6                                       | V                  |
| $t_{\text{flb}}$                     | 270                                       | $\mu\text{s}$      |
| $P_{\text{tot}}$                     | 3.65                                      | W                  |
| $P_{\text{defl}}$                    | 0.9                                       | W                  |
| $P_{\text{IC}}$                      | 2.75                                      | W                  |
| $R_{\text{th(tot)}}$                 | 12  | K/W                |
| $T_{\text{j(max)}}^{(2)}$            | +83                                       | $^{\circ}\text{C}$ |

## Notes

- A layer of silicon grease between the mounting base and the heatsink optimizes thermal resistance.
- $T_{\text{j(max)}} = P_{\text{IC}} \times [R_{\text{th(j-mb)}} + R_{\text{th(mb-amb)}}] + T_{\text{amb}}$

Calculation formula for supply voltage and power consumption

$$V_{b1} = V_{6,3} + R_{\text{deflcoil}} \times I_{\text{defl(max)}} - U'_L + R_m \times I_{\text{defl(max)}} + V_4$$

$$V_{b2} = V_6 + R_{\text{deflcoil}} \times I_{\text{defl(max)}} + U'_L + R_m \times I_{\text{defl(max)}} + V_{4,3}$$

for  $V_{b1} > V_{b2}$  :  $V_P = V_{b1}$

for  $V_{b2} > V_{b1}$  :  $V_P = V_{b2}$

with:

$$U'_L = L_{\text{deflcoil}} \times 2I_{\text{defl(max)}} \times f_v$$

$f_v$  = vertical deflection frequency.

$$P_{\text{tot}} = V_P \times \frac{I_{\text{defl(max)}}}{2} + V_P \times 0.03 \text{ A} + 0.1 \text{ W} + V_{\text{FB}} \times I_{\text{FB}}$$

$$P_{\text{defl}} = \frac{1}{3} (R_{\text{deflcoil}} + R_m) \times I_{\text{defl(max)}}^2$$

$$P_{\text{IC}} = P_{\text{tot}} - P_{\text{defl}}$$

$P_{\text{IC}}$  = power dissipation of the IC

$P_{\text{defl}}$  = power dissipation of the deflection coil

$P_{\text{tot}}$  = total power dissipation.

Calculation formula for flyback time ( $t_{\text{flb}}$ )

$$t_{\text{flb}} = \frac{L_{\text{deflcoil}}}{R_{\text{deflcoil}} + R_m} \times \ln \left( \frac{1 + \frac{(R_{\text{deflcoil}} + R_m) \times I_{\text{defl(max)}}}{V_{\text{FB}} + V_{7r} - V_{6r}}}{1 - \frac{(R_{\text{deflcoil}} + R_m) \times I_{\text{defl(max)}}}{V_{\text{FB}} - (V_{7f} - V_{6f})}} \right) + t_{\text{flb(off)}}$$

with:

$t_{\text{flb(off)}}$  = flyback switch off time = 50  $\mu\text{s}$  for this application ( $t_{\text{flb(off)}}$  depends on  $V_{\text{FB}}$ ,  $I_{\text{defl(max)}}$ ,  $L_{\text{deflcoil}}$  and  $C_{\text{SP}}$ ).

To achieve good noise suppression the following values for  $R_p$  are recommended:

## Recommended values

| $L_{\text{deflcoil}}$<br>(mH) | $R_p$<br>( $\Omega$ ) |
|-------------------------------|-----------------------|
| 3                             | 100                   |
| 6                             | 180                   |
| 10                            | 240                   |
| 15                            | 390                   |



Full bridge current driven vertical deflection booster

TDA4866

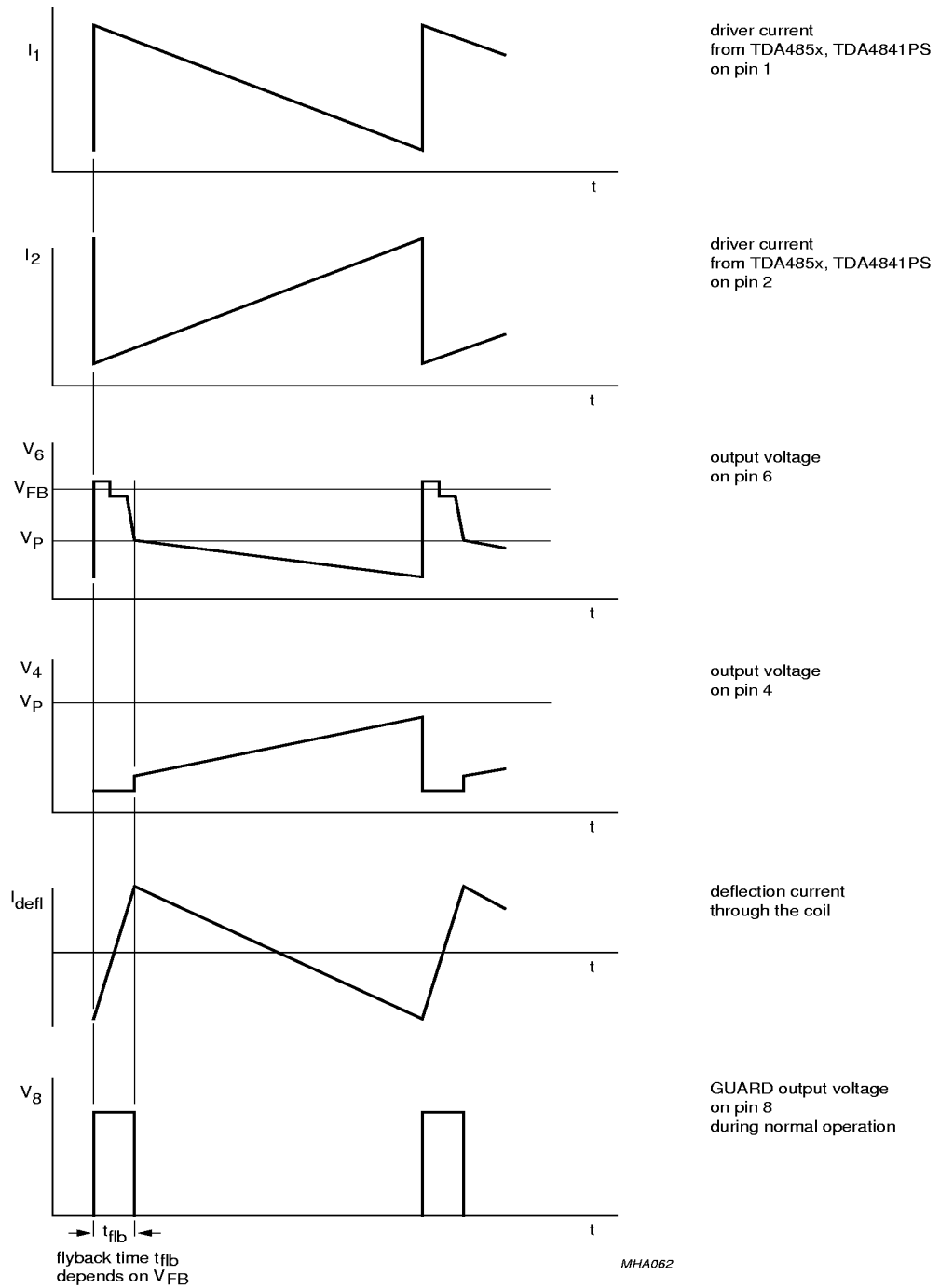

flyback time t<sub>flyb</sub> depends on V<sub>FB</sub>

MHA062

Fig.5 Timing diagram.

Full bridge current driven vertical deflection booster

TDA4866

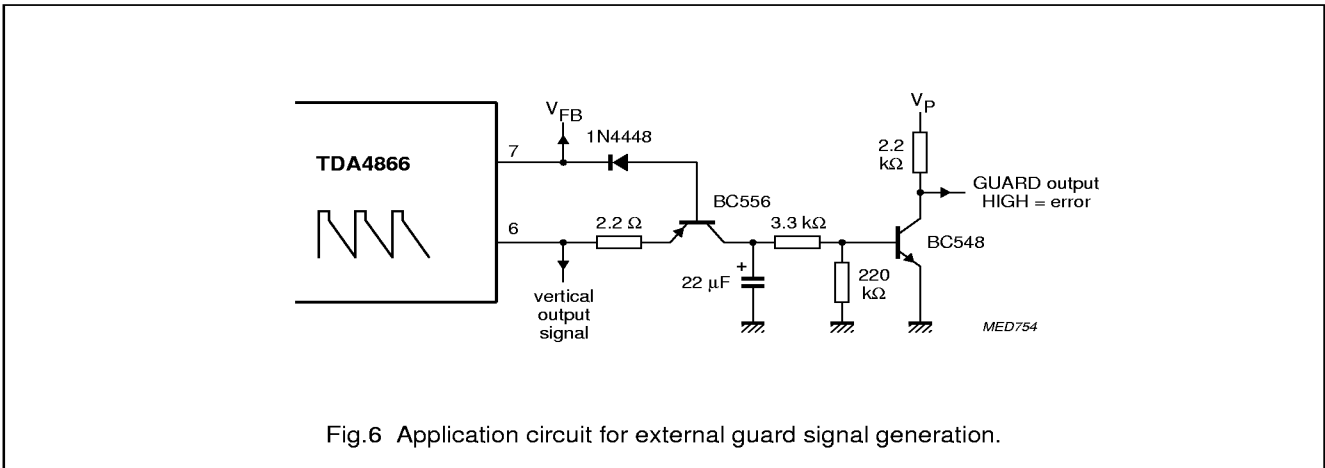

INTERNAL PIN CONFIGURATION

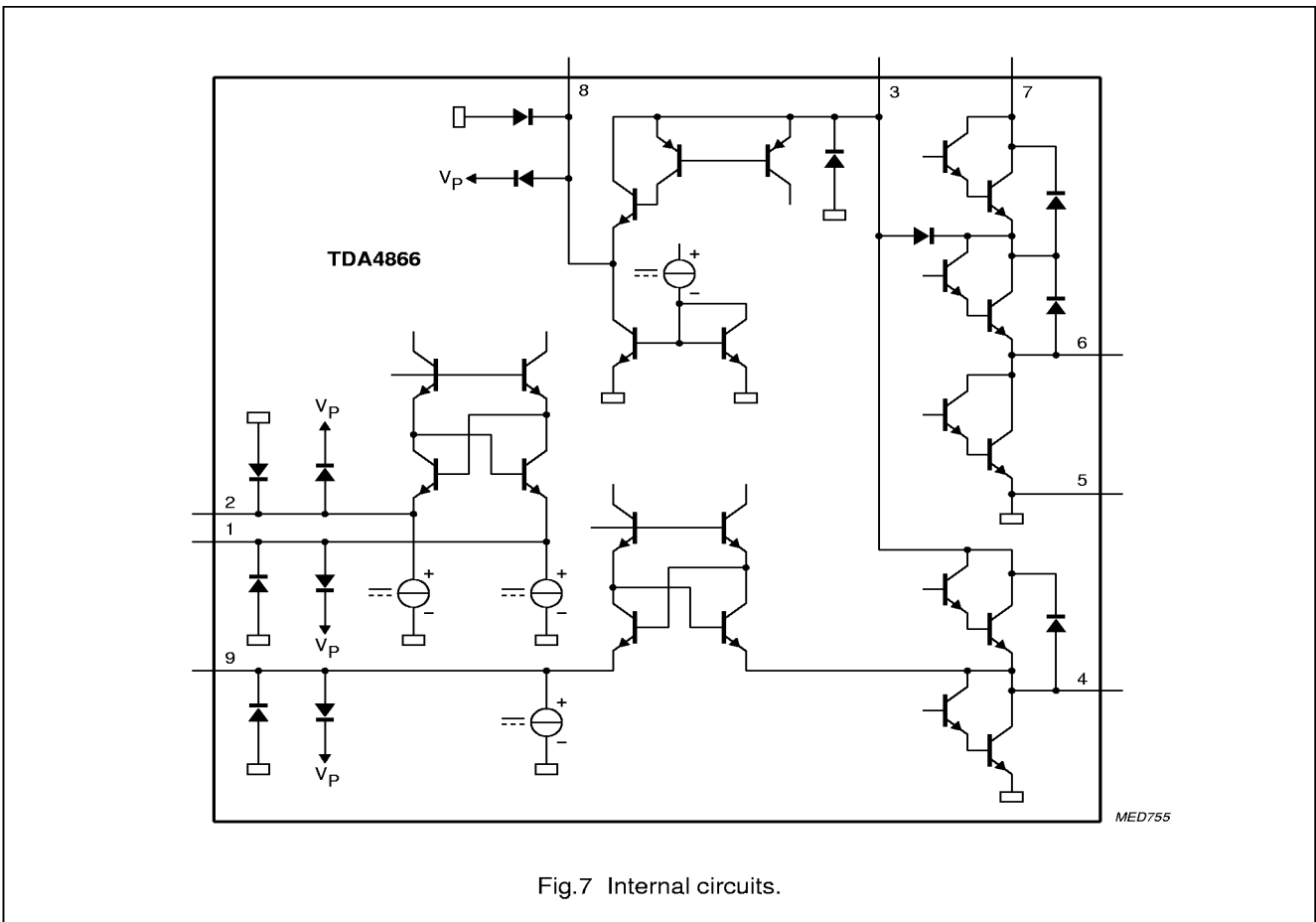

# Full bridge current driven vertical deflection booster

TDA4866

## PACKAGE OUTLINE

SIL9P: plastic single in-line power package; 9 leads

SOT131-2

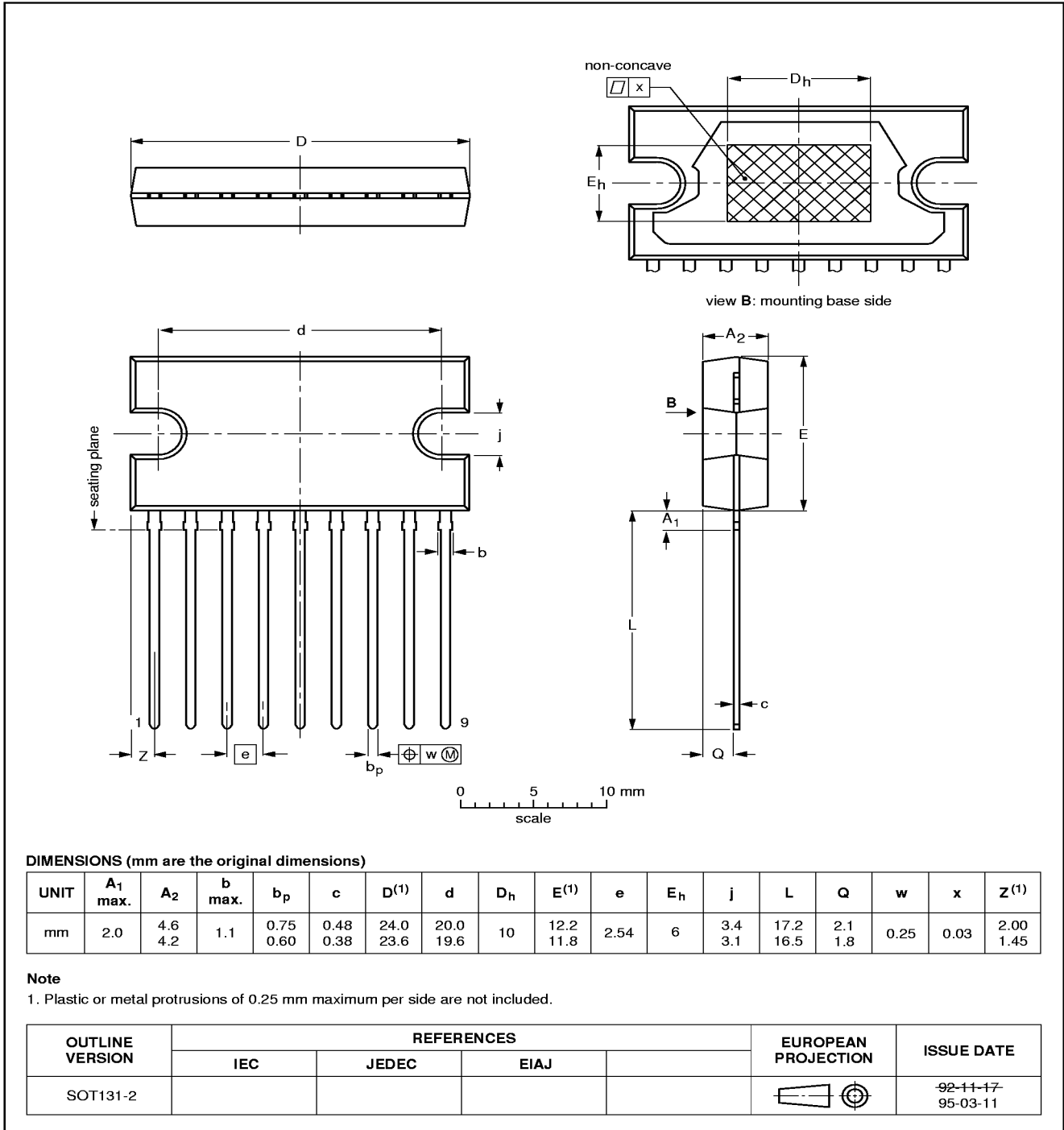

## Full bridge current driven vertical deflection booster

TDA4866

### SOLDERING

#### Introduction to soldering through-hole mount packages

This text gives a brief insight to wave, dip and manual soldering. A more in-depth account of soldering ICs can be found in our "Data Handbook IC26; Integrated Circuit Packages" (document order number 9398 652 90011).

Wave soldering is the preferred method for mounting of through-hole mount IC packages on a printed-circuit board.

#### Soldering by dipping or by solder wave

The maximum permissible temperature of the solder is 260 °C; solder at this temperature must not be in contact with the joints for more than 5 seconds.

The total contact time of successive solder waves must not exceed 5 seconds.

The device may be mounted up to the seating plane, but the temperature of the plastic body must not exceed the specified maximum storage temperature ( $T_{stg(max)}$ ). If the printed-circuit board has been pre-heated, forced cooling may be necessary immediately after soldering to keep the temperature within the permissible limit.

#### Manual soldering

Apply the soldering iron (24 V or less) to the lead(s) of the package, either below the seating plane or not more than 2 mm above it. If the temperature of the soldering iron bit is less than 300 °C it may remain in contact for up to 10 seconds. If the bit temperature is between 300 and 400 °C, contact may be up to 5 seconds.

#### Suitability of through-hole mount IC packages for dipping and wave soldering methods

| PACKAGE                   | SOLDERING METHOD |                         |
|---------------------------|------------------|-------------------------|
|                           | DIPPING          | WAVE                    |
| DBS, DIP, HDIP, SDIP, SIL | suitable         | suitable <sup>(1)</sup> |

#### Note

- For SDIP packages, the longitudinal axis must be parallel to the transport direction of the printed-circuit board.

### DEFINITIONS

| Data sheet status   |   |
|---|---|
| Objective specification   | This data sheet contains target or goal specifications for product development.       |
| Preliminary specification   | This data sheet contains preliminary data; supplementary data may be published later. |
| Product specification   | This data sheet contains final product specifications.                                |
| Limiting values   |   |
| Limiting values given are in accordance with the Absolute Maximum Rating System (IEC 134). Stress above one or more of the limiting values may cause permanent damage to the device. These are stress ratings only and operation of the device at these or at any other conditions above those given in the Characteristics sections of the specification is not implied. Exposure to limiting values for extended periods may affect device reliability. |   |
| Application information   |   |
| Where application information is given, it is advisory and does not form part of the specification.   |   |

### LIFE SUPPORT APPLICATIONS

These products are not designed for use in life support appliances, devices, or systems where malfunction of these products can reasonably be expected to result in personal injury. Philips customers using or selling these products for use in such applications do so at their own risk and agree to fully indemnify Philips for any damages resulting from such improper use or sale.