

LM833

Dual Audio Operational Amplifier

General Description

The LM833 is a dual general purpose operational amplifier designed with particular emphasis on performance in audio systems.

This dual amplifier IC utilizes new circuit and processing techniques to deliver low noise, high speed and wide bandwidth without increasing external components or decreasing stability. The LM833 is internally compensated for all closed loop gains and is therefore optimized for all preamp and high level stages in PCM and HiFi systems.

The LM833 is pin-for-pin compatible with industry standard dual operational amplifiers.

Features

- Wide dynamic range: 140dB
- Low input noise voltage: 4.5nV/ $\sqrt{\text{Hz}}$
- High slew rate: 7 V/ μs (typ); 5V/ μs (min)
- High gain bandwidth: 15MHz (typ); 10MHz (min)
- Wide power bandwidth: 120KHz
- Low distortion: 0.002%
- Low offset voltage: 0.3mV
- Large phase margin: 60°
- Available in 8 pin MSOP package

Schematic Diagram (1/2 LM833)

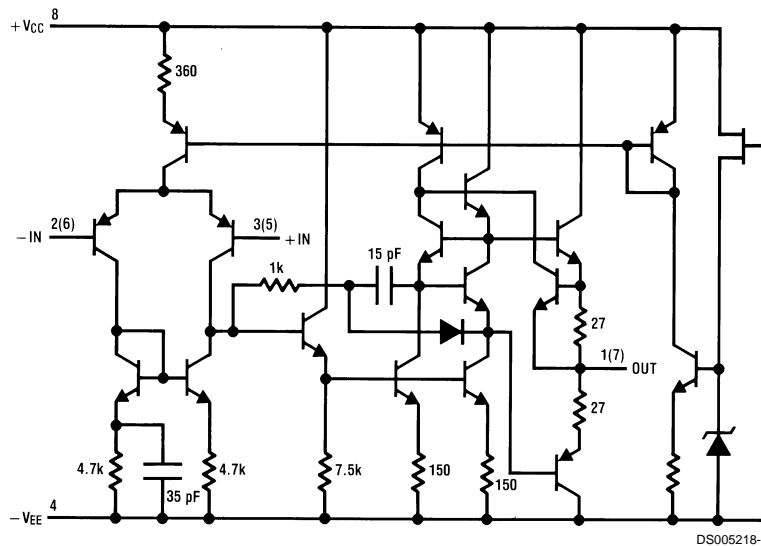

Connection Diagram

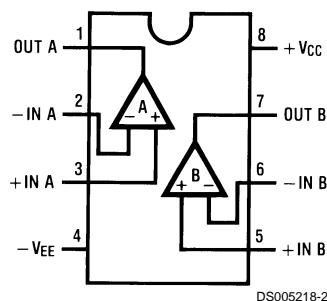

Order Number LM833M, LM833MX, LM833N, LM833MM or LM833MMX
See NS Package Number
M08A, N08E or MUA08A

Absolute Maximum Ratings (Note 1)

If Military/Aerospace specified devices are required, please contact the National Semiconductor Sales Office/Distributors for availability and specifications.

Supply Voltage $V_{CC}-V_{EE}$	36V
Differential Input Voltage (Note 3) V_I	$\pm 30V$
Input Voltage Range (Note 3) V_{IC}	$\pm 15V$
Power Dissipation (Note 4) P_D	500 mW
Operating Temperature Range T_{OPR}	$-40 \sim 85^\circ C$
Storage Temperature Range T_{STG}	$-60 \sim 150^\circ C$

Soldering Information

Dual-In-Line Package Soldering (10 seconds)	260°C
Small Outline Package (SOIC and MSOP) Vapor Phase (60 seconds)	215°C
Infrared (15 seconds)	220°C
See AN-450 "Surface Mounting Methods and Their Effect on Product Reliability" for other methods of soldering surface mount devices.	
ESD tolerance (Note 5)	1600V

DC Electrical Characteristics (Notes 1, 2)

($T_A = 25^\circ C$, $V_S = \pm 15V$)

Symbol	Parameter	Conditions	Min	Typ	Max	Units
V_{OS}	Input Offset Voltage	$R_S = 10\Omega$		0.3	5	mV
I_{OS}	Input Offset Current			10	200	nA
I_B	Input Bias Current			500	1000	nA
A_V	Voltage Gain	$R_L = 2\text{ k}\Omega$, $V_O = \pm 10V$	90	110		dB
V_{OM}	Output Voltage Swing	$R_L = 10\text{ k}\Omega$ $R_L = 2\text{ k}\Omega$	± 12 ± 10	± 13.5 ± 13.4		V V
V_{CM}	Input Common-Mode Range		± 12	± 14.0		V
CMRR	Common-Mode Rejection Ratio	$V_{IN} = \pm 12V$	80	100		dB
PSRR	Power Supply Rejection Ratio	$V_S = 15\sim 5V$, $-15\sim -5V$	80	100		dB
I_Q	Supply Current	$V_O = 0V$, Both Amps		5	8	mA

AC Electrical Characteristics

($T_A = 25^\circ C$, $V_S = \pm 15V$, $R_L = 2\text{ k}\Omega$)

Symbol	Parameter	Conditions	Min	Typ	Max	Units
SR	Slew Rate	$R_L = 2\text{ k}\Omega$	5	7		V/ μs
GBW	Gain Bandwidth Product	$f = 100\text{ kHz}$	10	15		MHz

Design Electrical Characteristics

($T_A = 25^\circ C$, $V_S = \pm 15V$)

The following parameters are not tested or guaranteed.

Symbol	Parameter	Conditions	Typ	Units
$\Delta V_{OS}/\Delta T$	Average Temperature Coefficient of Input Offset Voltage		2	$\mu V/^\circ C$
THD	Distortion	$R_L = 2\text{ k}\Omega$, $f = 20\sim 20\text{ kHz}$ $V_{OUT} = 3\text{ V}_{rms}$, $A_V = 1$	0.002	%
e_n	Input Referred Noise Voltage	$R_S = 100\Omega$, $f = 1\text{ kHz}$	4.5	nV/\sqrt{Hz}
i_n	Input Referred Noise Current	$f = 1\text{ kHz}$	0.7	pA/\sqrt{Hz}
PBW	Power Bandwidth	$V_O = 27\text{ V}_{pp}$, $R_L = 2\text{ k}\Omega$, $THD \leq 1\%$	120	kHz
f_U	Unity Gain Frequency	Open Loop	9	MHz
ϕ_M	Phase Margin	Open Loop	60	deg
	Input Referred Cross Talk	$f = 20\sim 20\text{ kHz}$	-120	dB

Design Electrical Characteristics (Continued)

Note 1: *Absolute Maximum Ratings* indicate limits beyond which damage to the device may occur. *Operating Ratings* indicate conditions for which the device is functional, but do not guarantee specific performance limits. *Electrical Characteristics* state DC and AC electrical specifications under particular test conditions which guarantee specific performance limits. This assumes that the device is within the Operating Ratings. Specifications are not guaranteed for parameters where no limit is given, however, the typical value is a good indication of device performance.

Note 2: All voltages are measured with respect to the ground pin, unless otherwise specified.

Note 3: If supply voltage is less than $\pm 15V$, it is equal to supply voltage.

Note 4: This is the permissible value at $T_A \leq 85^\circ C$.

Note 5: Human body model, 1.5 k Ω in series with 100 pF.

Typical Performance Characteristics

Maximum Power Dissipation vs Ambient Temperature

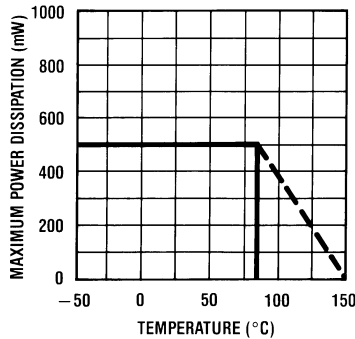

Input Bias Current vs Ambient Temperature

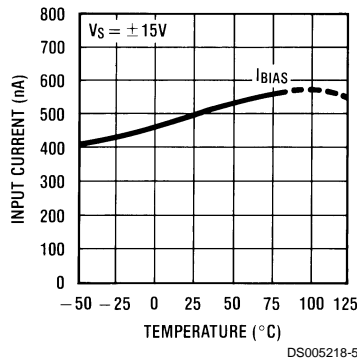

Input Bias Current vs Supply Voltage

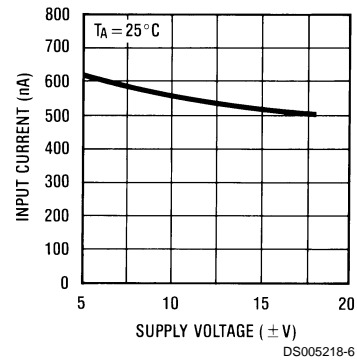

Supply Current vs Supply Voltage

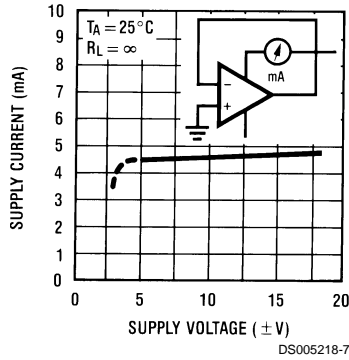

DC Voltage Gain vs Ambient Temperature

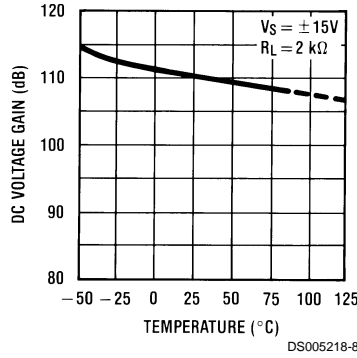

DC Voltage Gain vs Supply Voltage

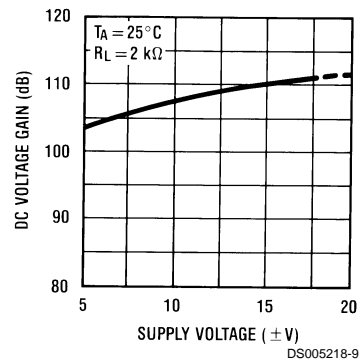

Voltage Gain & Phase vs Frequency

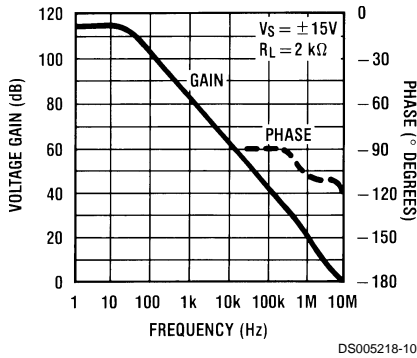

Gain Bandwidth Product vs Ambient Temperature

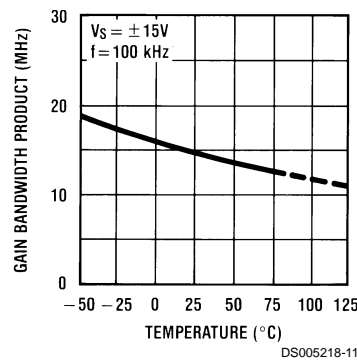

Gain Bandwidth vs Supply Voltage

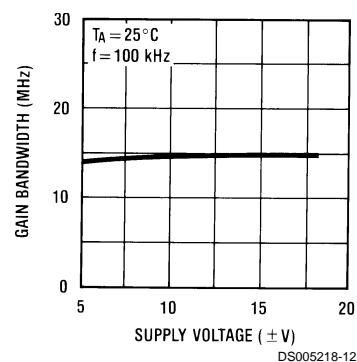

Typical Performance Characteristics (Continued)

Slew Rate vs Ambient Temperature

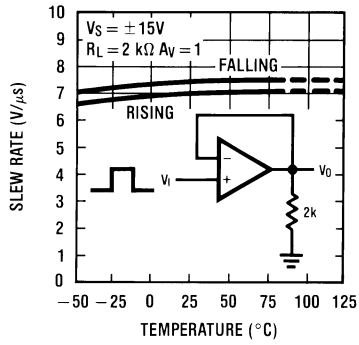

Slew Rate vs Supply Voltage

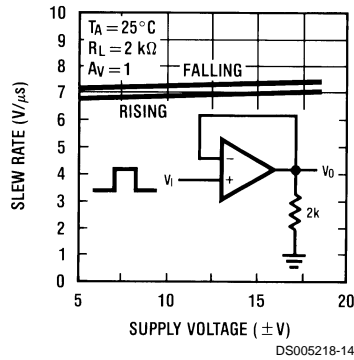

Power Bandwidth

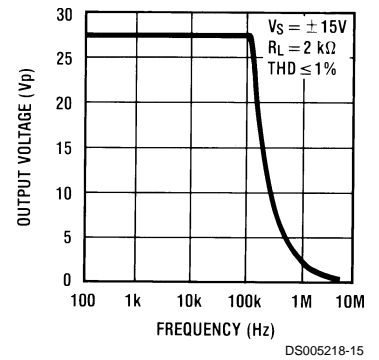

CMR vs Frequency

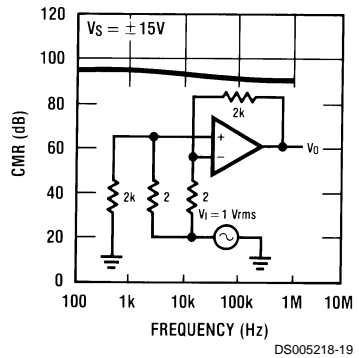

Distortion vs Frequency

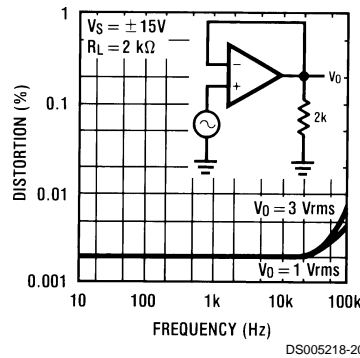

PSRR vs Frequency

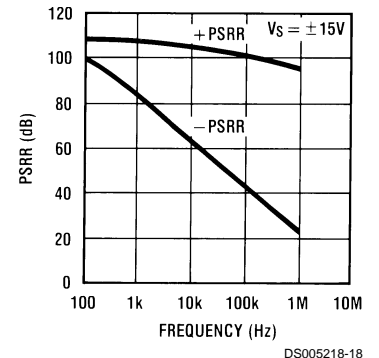

Maximum Output Voltage vs Supply Voltage

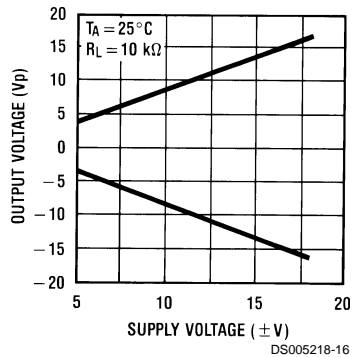

Maximum Output Voltage vs Ambient Temperature

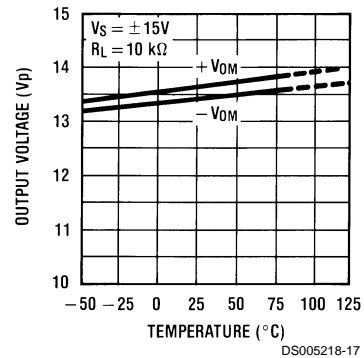

Typical Performance Characteristics (Continued)

Spot Noise Voltage vs Frequency

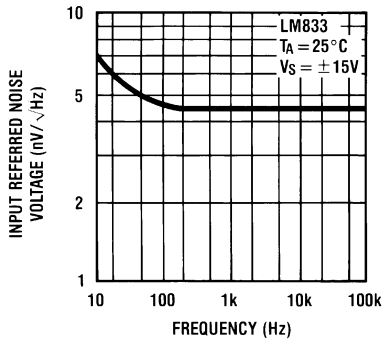

DS005218-21

Spot Noise Current vs Frequency

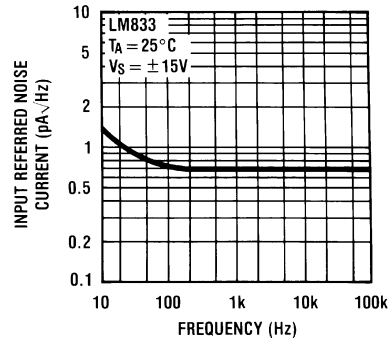

DS005218-22

Input Referred Noise Voltage vs Source Resistance

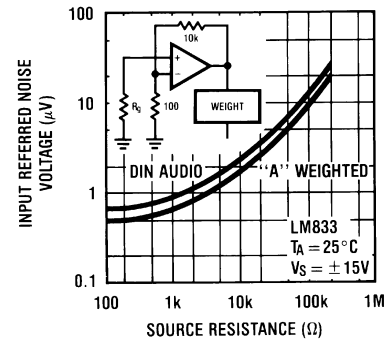

DS005218-23

Noninverting Amp

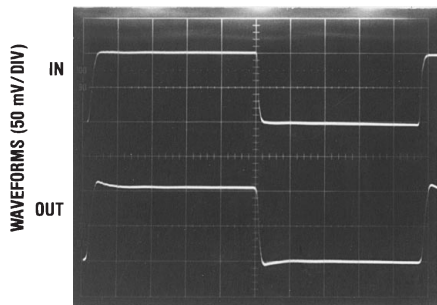

TIME (0.2 μs/DIV)

DS005218-24

Noninverting Amp

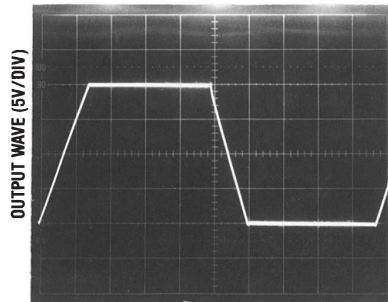

TIME (2 μs/DIV)

DS005218-25

Inverting Amp

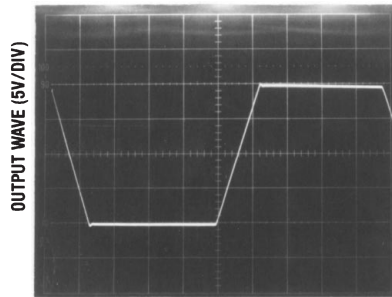

TIME (2 μs/DIV)

DS005218-26

Application Hints

The LM833 is a high speed op amp with excellent phase margin and stability. Capacitive loads up to 50 pF will cause little change in the phase characteristics of the amplifiers and are therefore allowable.

Capacitive loads greater than 50 pF must be isolated from the output. The most straightforward way to do this is to put a resistor in series with the output. This resistor will also prevent excess power dissipation if the output is accidentally shorted.

Noise Measurement Circuit

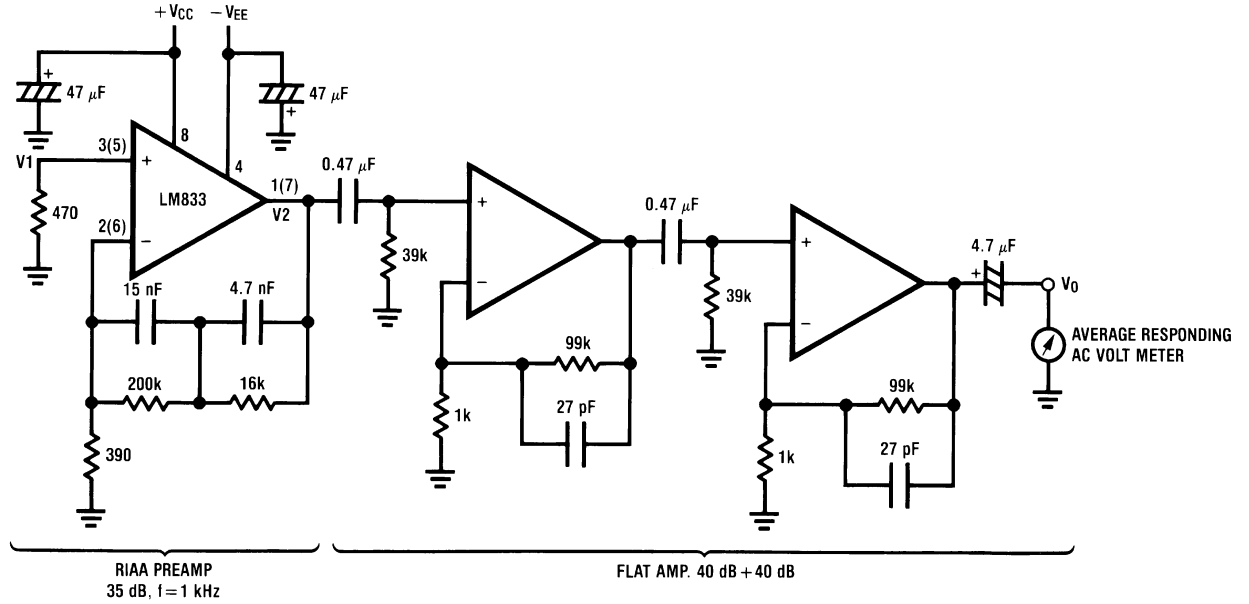

DS005218-27

Complete shielding is required to prevent induced pick up from external sources. Always check with oscilloscope for power line noise.

Total Gain: 115 dB @f = 1 kHz
Input Referred Noise Voltage: $e_n = V_0/560,000$ (V)

RIAA Preamp Voltage Gain, RIAA Deviation vs Frequency

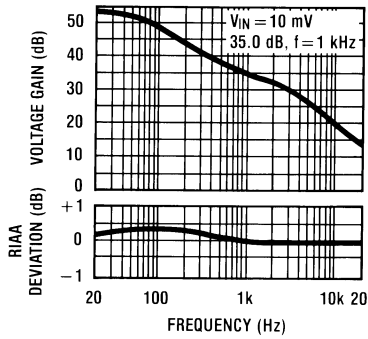

Flat Amp Voltage Gain vs Frequency

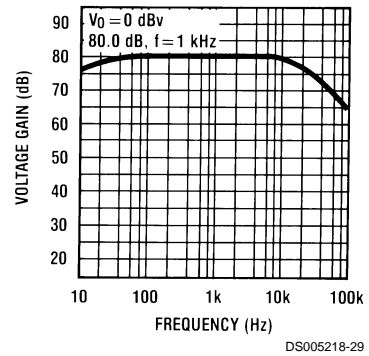

Typical Applications

NAB Preamp

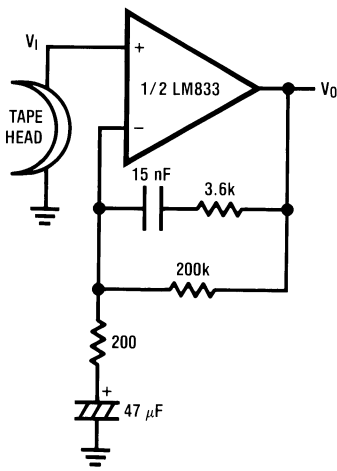

DS005218-30

$A_V = 34.5$
 $F = 1 \text{ kHz}$
 $E_n = 0.38 \mu\text{V}$
 A Weighted

NAB Preamp Voltage Gain vs Frequency

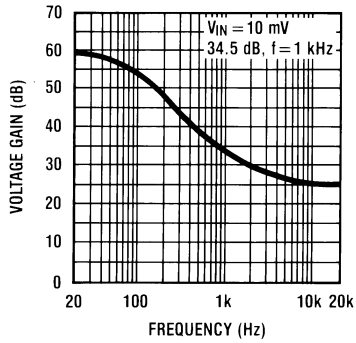

DS005218-31

Adder/Subtractor

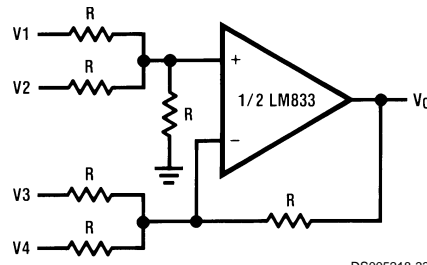

DS005218-33

$$V_O = V_1 + V_2 - V_3 - V_4$$

Sine Wave Oscillator

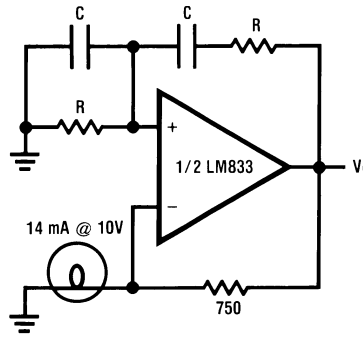

DS005218-34

$$f_o = \frac{1}{2\pi RC}$$

Balanced to Single Ended Converter

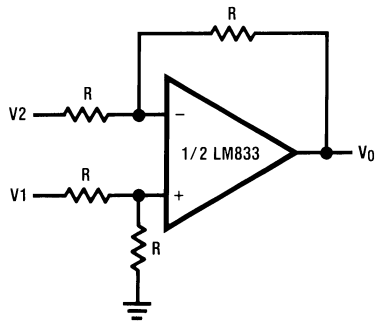

DS005218-32

$$V_O = V_1 - V_2$$

Typical Applications (Continued)

Second Order High Pass Filter (Butterworth)

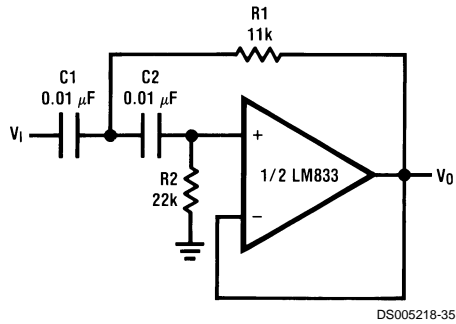

if $C1 = C2 = C$

$$R1 = \frac{\sqrt{2}}{2\omega_0 C}$$

$$R2 = 2 \cdot R1$$

Illustration is $f_0 = 1 \text{ kHz}$

Second Order Low Pass Filter (Butterworth)

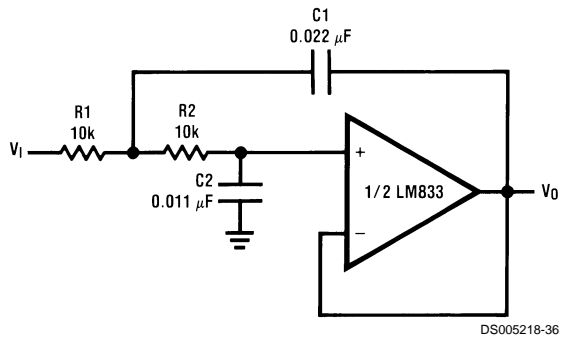

if $R1 = R2 = R$

$$C1 = \frac{\sqrt{2}}{\omega_0 R}$$

$$C2 = \frac{C1}{2}$$

Illustration is $f_0 = 1 \text{ kHz}$

Typical Applications (Continued)

State Variable Filter

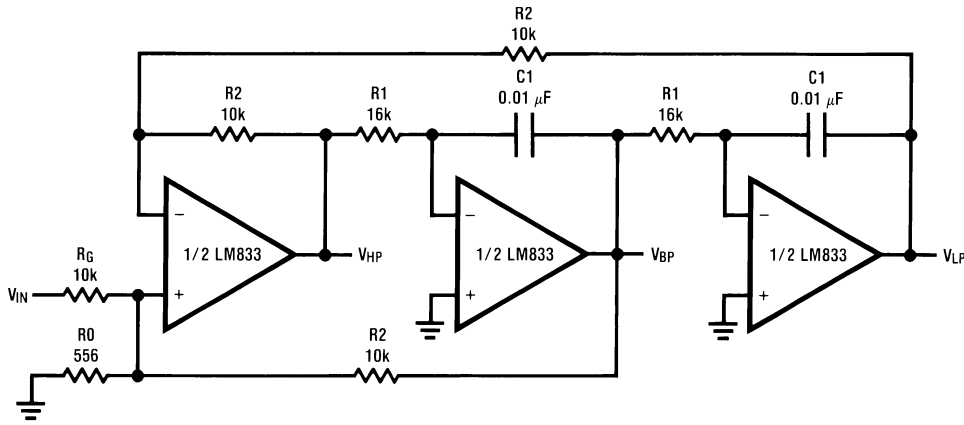

DS005218-37

$$f_0 = \frac{1}{2\pi C1 R1}, Q = \frac{1}{2} \left(1 + \frac{R2}{R0} + \frac{R2}{RG} \right), A_{BP} = Q A_{LP} = Q A_{LH} = \frac{R2}{RG}$$

Illustration is $f_0 = 1 \text{ kHz}, Q = 10, A_{BP} = 1$

AC/DC Converter

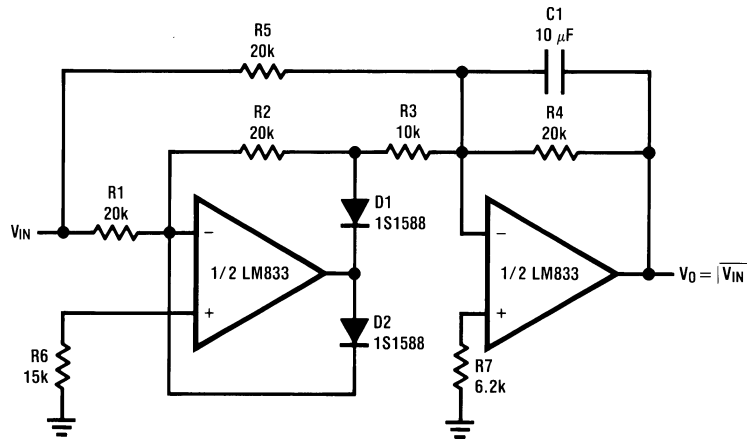

DS005218-38

2 Channel Panning Circuit (Pan Pot)

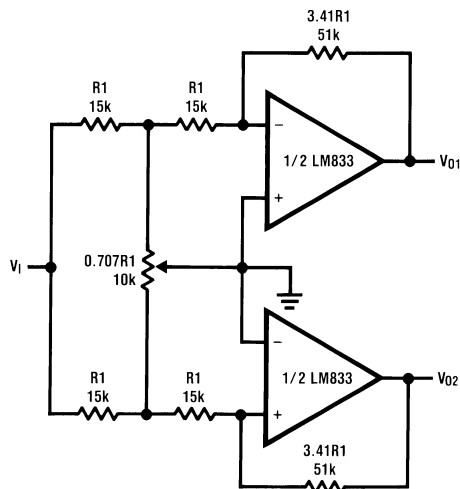

DS005218-39

Line Driver

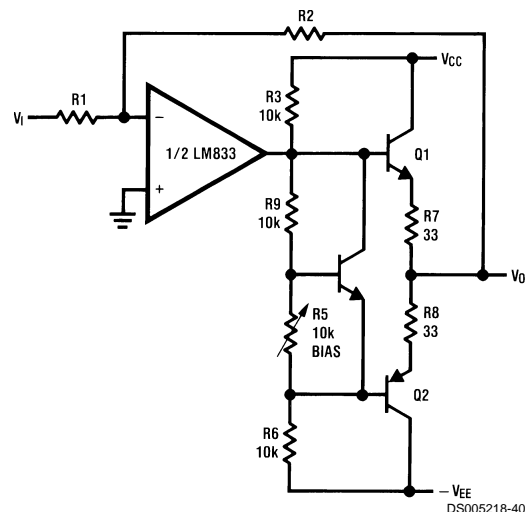

DS005218-40

Typical Applications (Continued)

Tone Control

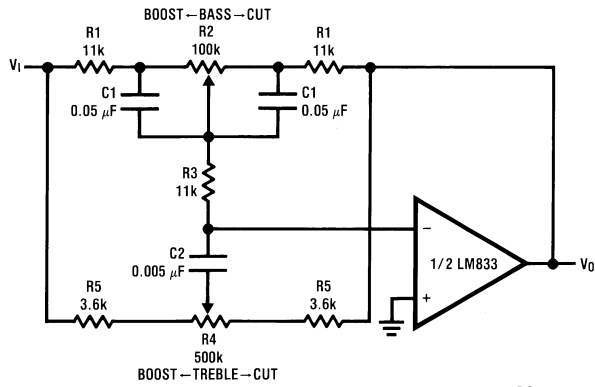

DS005218-41

$$f_L = \frac{1}{2\pi R_2 C_1}, f_{LB} = \frac{1}{2\pi R_1 C_1}$$

$$f_H = \frac{1}{2\pi R_5 C_2}, f_{HB} = \frac{1}{2\pi (R_1 + R_5 + 2R_3) C_2}$$

Illustration is:

$$f_L = 32 \text{ Hz}, f_{LB} = 320 \text{ Hz}$$

$$f_H = 11 \text{ kHz}, f_{HB} = 1.1 \text{ kHz}$$

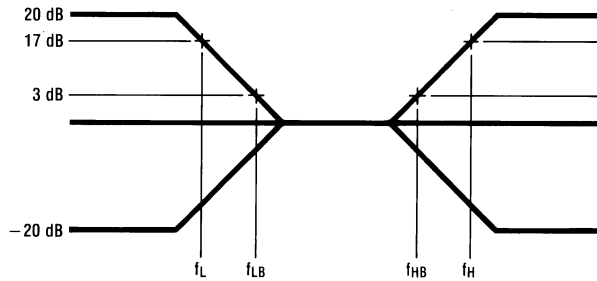

DS005218-42

RIIA Preamp

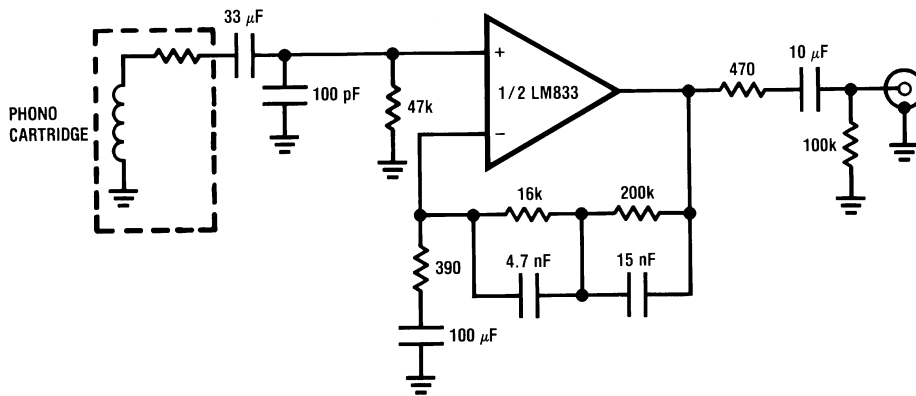

DS005218-3

$A_v = 35 \text{ dB}$
 $E_n = 0.33 \mu\text{V}$
 $S/N = 90 \text{ dB}$
 $f = 1 \text{ kHz}$
 A Weighted
 A Weighted, $V_{IN} = 10 \text{ mV}$
 @ $f = 1 \text{ kHz}$

Typical Applications (Continued)

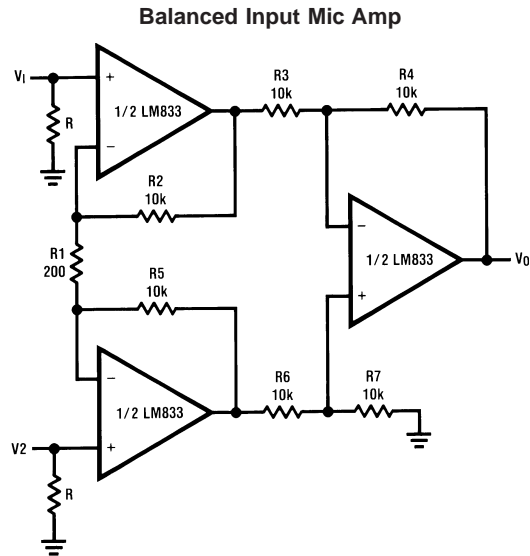

If $R2 = R5$, $R3 = R6$, $R4 = R7$

$$V_0 = \left(1 + \frac{2R_2}{R_1} \right) \frac{R_4}{R_3} (V_2 - V_1)$$

Illustration is:

$$V_0 = 101(V_2 - V_1)$$

Typical Applications (Continued)

10 Band Graphic Equalizer

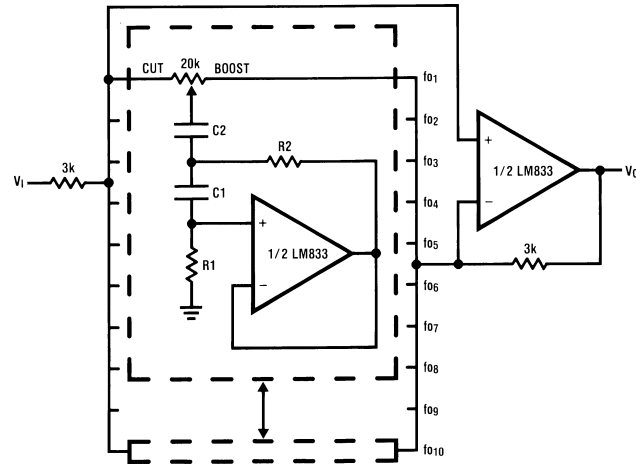

DS005218-44

fo(Hz)	C ₁	C ₂	R ₁	R ₂
32	0.12μF	4.7μF	75kΩ	500Ω
64	0.056μF	3.3μF	68kΩ	510Ω
125	0.033μF	1.5μF	62kΩ	510Ω
250	0.015μF	0.82μF	68kΩ	470Ω
500	8200pF	0.39μF	62kΩ	470Ω
1k	3900pF	0.22μF	68kΩ	470Ω
2k	2000pF	0.1μF	68kΩ	470Ω
4k	1100pF	0.056μF	62kΩ	470Ω
8k	510pF	0.022μF	68kΩ	510Ω
16k	330pF	0.012μF	51kΩ	510Ω

Note 6: At volume of change = ±12 dB

Q = 1.7

Reference: "AUDIO/RADIO HANDBOOK", National Semiconductor, 1980, Page 2-61

Physical Dimensions inches (millimeters) unless otherwise noted

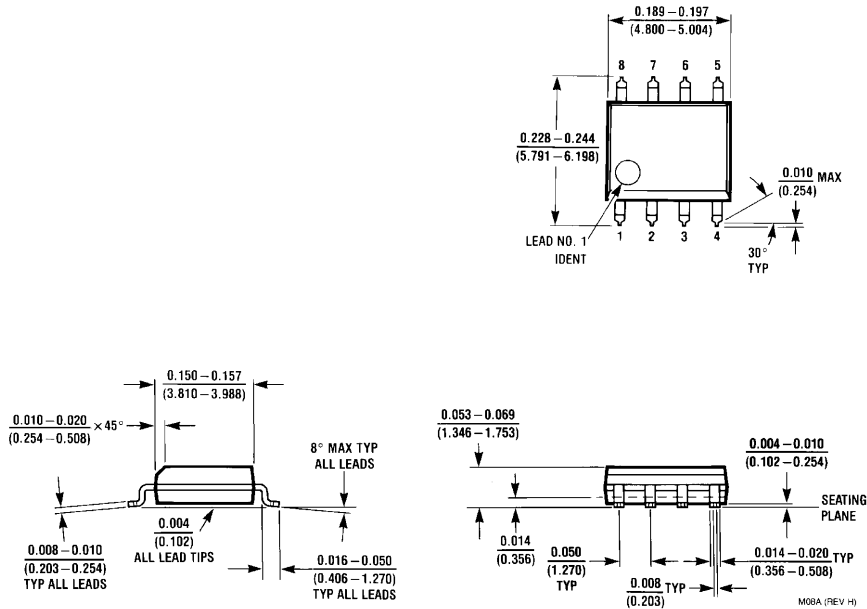

Molded Small Outline Package (M)
Order Number LM833M or LM833MX
NS Package Number M08A

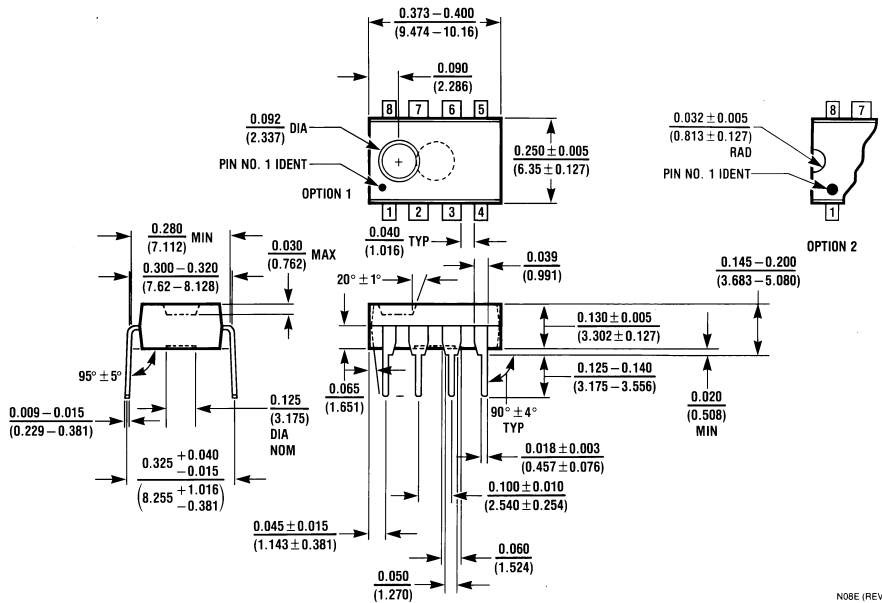

Molded Dual-In-Line Package (N)
Order Number LM833N
NS Package Number N08E

Physical Dimensions inches (millimeters) unless otherwise noted (Continued)

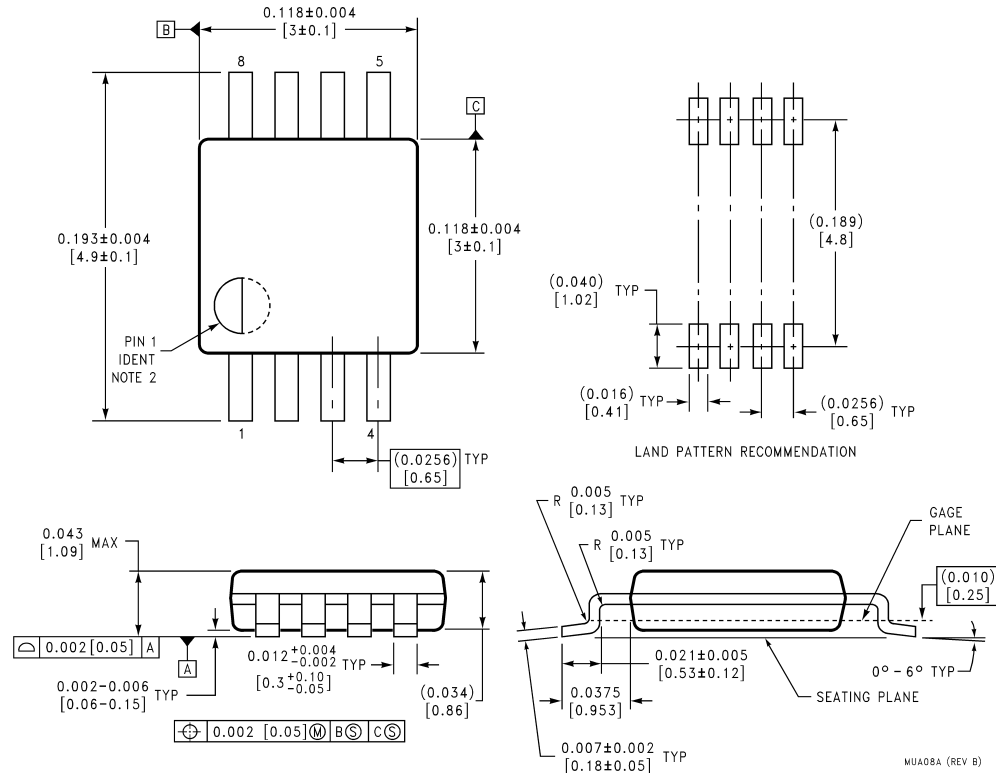

8-Lead (0.118" Wide) Molded Mini Small Outline Package
Order Number LM833MM or LM833MMX
NS Package Number MUA08A

LIFE SUPPORT POLICY

NATIONAL'S PRODUCTS ARE NOT AUTHORIZED FOR USE AS CRITICAL COMPONENTS IN LIFE SUPPORT DEVICES OR SYSTEMS WITHOUT THE EXPRESS WRITTEN APPROVAL OF THE PRESIDENT AND GENERAL COUNSEL OF NATIONAL SEMICONDUCTOR CORPORATION. As used herein:

1. Life support devices or systems are devices or systems which, (a) are intended for surgical implant into the body, or (b) support or sustain life, and whose failure to perform when properly used in accordance with instructions for use provided in the labeling, can be reasonably expected to result in a significant injury to the user.
2. A critical component is any component of a life support device or system whose failure to perform can be reasonably expected to cause the failure of the life support device or system, or to affect its safety or effectiveness.

 **National Semiconductor Corporation**
Americas
Tel: 1-800-272-9959
Fax: 1-800-737-7018
Email: support@nsc.com
www.national.com

National Semiconductor Europe
Fax: +49 (0) 180-530 85 86
Email: europe.support@nsc.com
Deutsch Tel: +49 (0) 69 9508 6208
English Tel: +44 (0) 870 24 0 2171
Français Tel: +33 (0) 1 41 91 87 90

National Semiconductor Asia Pacific Customer Response Group
Tel: 65-2544466
Fax: 65-2504466
Email: ap.support@nsc.com

National Semiconductor Japan Ltd.
Tel: 81-3-5639-7560
Email: nsj.crc@jksmtp.nsc.com
Fax: 81-3-5639-7507